

CLICK and LOCK RISER TECHNOLOGY

The EZsnap riser is designed to create an easy-to-assemble watertight riser system for septic tanks, pump tanks, and cisterns.

The EZsnap Riser features click and lock technology eliminating the need for assembly tools, sealant/caulk and hardware. The 24" diameter EZsnap Riser is available in 2", 6" and 12" tall sections that nest together making for efficient storage and shipping.



**EZSNAP RISERS
FOR USE WITH
1530 & 1060 TANKS
JULY 2018 OR NEWER**

2, 6 & 12 Inch Riser System Available in Green and Black

- A. 24" x 2" Risers
- B. 24" x 6" Risers
- C. 24" x 12" Risers
- D. 24" Lids
- E. 24" Adapter Rings
- F. 24" Safety Star

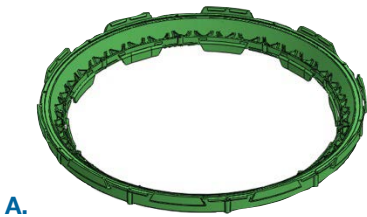

A.



D.

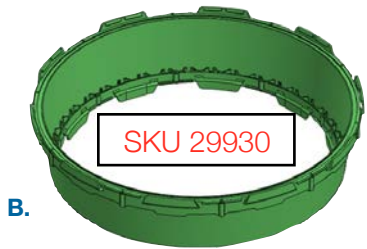

B.

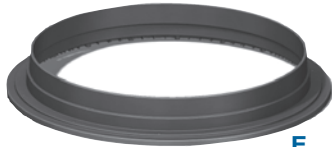

E.

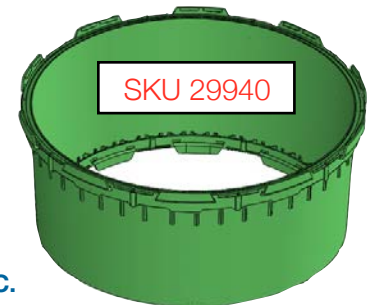

C.



F.

WATERTIGHT GASKET TO GASKET CONNECTION
USE WITH ORIGINAL LID

Benefits

- Easy to Assemble
- No Tools or Adhesive
- Watertight – Gasketed Connection
- Nest Together for Efficient Shipping
- Available in 2, 6 and 12 Inch Heights
- Strong, Durable, Polypropylene Construction
- Available in Green or Black

EZSnap Riser System Sizes and Specifications

EZSnap Riser Specifications

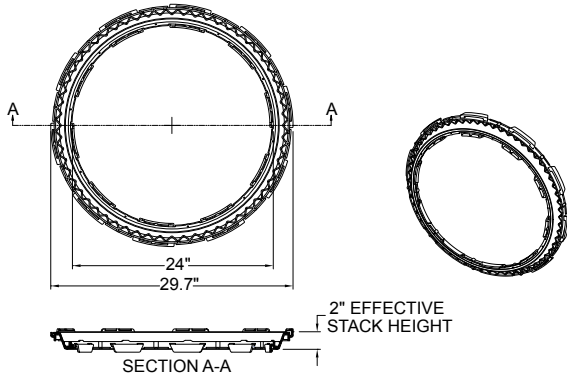

EZSnap Safety Star Specifications

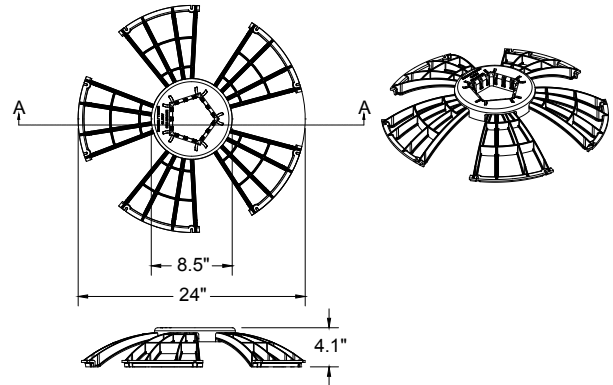

EZSnap 24" Lid Specifications

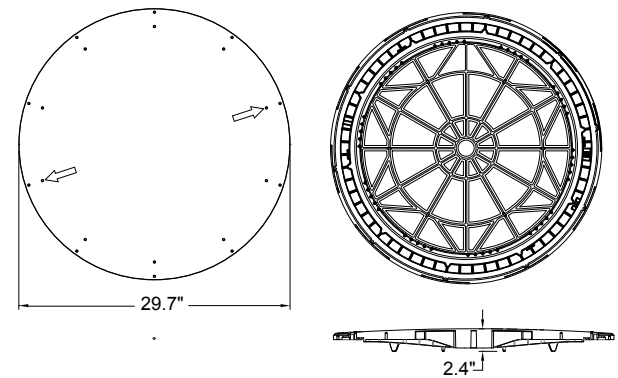
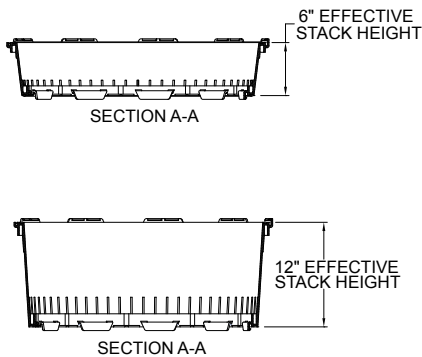

INFILTRATOR WATER TECHNOLOGIES, LLC ("Infiltrator") EZsnap by Infiltrator LIMITED WARRANTY ONE (1) YEAR MATERIALS AND WORKMANSHIP LIMITED WARRANTY

(a) This limited warranty is extended to the end user of an EZsnap by Infiltrator riser and lid system and other accessories.

An EZsnap system manufactured by Infiltrator, when installed and operated in accordance with Infiltrator's installation instructions and local regulation by a licensed installer, is warranted to you: (i) against defective materials and workmanship for one (1) year after installation. Infiltrator will, at its option, (i) repair the defective product or (ii) replace the defective materials. Infiltrator's liability specifically excludes the cost of removal and/or installation of the EZsnap system.

(b) In order to exercise its warranty rights, you must notify Infiltrator in writing at its corporate headquarters in Old Saybrook, Connecticut within fifteen (15) days of the alleged defect.

(c) YOUR EXCLUSIVE REMEDY WITH RESPECT TO ANY AND ALL LOSSES OR DAMAGES RESULTING FROM ANY CAUSE WHATSOEVER SHALL BE SPECIFIED IN SUBPARAGRAPH (a) ABOVE. INFILTRATOR SHALL IN NO EVENT BE LIABLE FOR ANY CONSEQUENTIAL OR INCIDENTAL DAMAGES OF ANY KIND, HOWEVER OCCASIONED, WHETHER BY NEGLIGENCE OR OTHERWISE. SOME STATES DO NOT ALLOW THE EXCLUSION OR LIMITATION OF INCIDENTAL OR CONSEQUENTIAL DAMAGES, SO THIS LIMITATION OR EXCLUSION MAY NOT APPLY TO YOU. THIS WARRANTY GIVES YOU SPECIFIC LEGAL RIGHTS AND YOU MAY ALSO HAVE OTHER RIGHTS WHICH VARY FROM STATE TO STATE.

(d) THIS LIMITED WARRANTY IS THE EXCLUSIVE WARRANTY GIVEN BY INFILTRATOR AND SUPERSEDES ANY PRIOR, CONTRARY, ADDITIONAL, OR SUBSEQUENT REPRESENTATIONS, WHETHER ORAL OR WRITTEN. INFILTRATOR DISCLAIMS AND EXCLUDES TO THE GREATEST EXTENT ALLOWED BY LAW ALL OTHER WARRANTIES, WHETHER EXPRESS OR IMPLIED, OR STATUTORY, INCLUDING ANY WARRANTY OF MERCHANTABILITY, FITNESS FOR A PARTICULAR PURPOSE AND ANY IMPLIED WARRANTIES OTHERWISE ARISING FROM COURSE OF DEALING, COURSE OF PERFORMANCE, OR USAGE OF TRADE. NO PERSON (INCLUDING ANY EMPLOYEE, AGENT, DEALER, OR REPRESENTATIVE) IS AUTHORIZED TO MAKE ANY REPRESENTATION OR WARRANTY CONCERNING THIS PRODUCT, EXCEPT TO REFER YOU TO THIS LIMITED WARRANTY. EXCEPT AS EXPRESSLY SET FORTH HEREIN, THIS WARRANTY IS NOT A WARRANTY OF FUTURE PERFORMANCE, BUT ONLY A WARRANTY TO REPAIR OR REPLACE.

(e) YOU MAY ASSIGN THIS LIMITED WARRANTY TO A SUBSEQUENT PURCHASER OF YOUR HOME.

(f) NO REPRESENTATIVE OF INFILTRATOR HAS THE AUTHORITY TO CHANGE THIS LIMITED WARRANTY IN ANY MANNER WHATSOEVER, OR TO EXTEND THIS LIMITED WARRANTY.

CONDITIONS AND EXCLUSIONS

There are certain conditions or applications over which Infiltrator has no control. Defects or problems as a result of such conditions or applications are not the responsibility of Infiltrator and are NOT covered under this warranty. They include failure to install the EZsnap system in accordance with instructions or applicable regulatory requirements or guidance, altering the EZsnap system contrary to the installation instructions and disposing of chemicals or other materials contrary to normal EZsnap system usage.

The above represents the Standard Limited Warranty offered by Infiltrator. A limited number of states and counties have different warranty requirements. Any purchaser of an EZsnap system should contact Infiltrator's corporate headquarters in Old Saybrook, Connecticut, prior to such purchase to obtain a copy of the applicable warranty, and should carefully read that warranty prior to the purchase of an EZsnap system.



4 Business Park Road
P.O. Box 768
Old Saybrook, CT 06475
860-577-7000 • Fax 860-577-7001
1-800-221-4436
www.infiltratorwater.com

U.S. Patents: 4,759,661; 5,017,041; 5,156,488; 5,336,017; 5,401,116; 5,401,459; 5,511,903; 5,716,163; 5,588,778; 5,839,844 Canadian Patents: 1,329,959; 2,004,564 Other patents pending. Infiltrator, Equalizer, Quick4, and SideWinder are registered trademarks of Infiltrator Water Technologies. Infiltrator is a registered trademark in France. Infiltrator Water Technologies is a registered trademark in Mexico. Contour, MicroLeaching, PolyTuff, ChamberSpacer, MultiPort, PosiLock, QuickCut, QuickPlay, SnapLock and StraightLock are trademarks of Infiltrator Water Technologies. PolyLok is a trademark of PolyLok, Inc. TUF-TITE is a registered trademark of TUF-TITE, INC. Ultra-Rib is a trademark of IPEX Inc.

© 2018 Infiltrator Water Technologies, LLC. All rights reserved. Printed in U.S.A.

EZSNAP01 0218

Contact Infiltrator Water Technologies' Technical Services Department for assistance at 1-800-221-4436